

D 06 F

Pressure reducing valve with balanced seat Standard pattern with set point scale

Product specification sheet

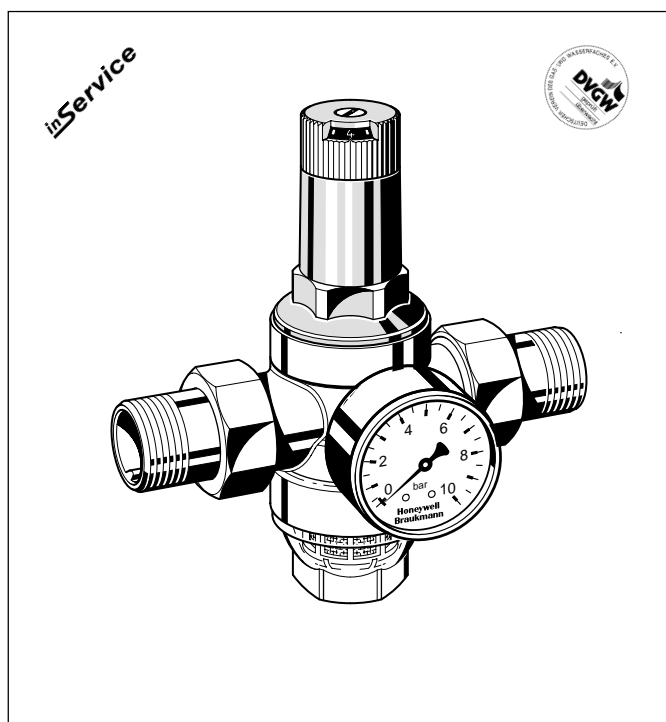

Application

D 06 F pressure reducing valves protect household water installations against excessive pressure from the supply. They can also be used for industrial or commercial applications within the range of their specification. By installing a pressure reducing valve, pressurisation damage is avoided and water consumption is reduced. The set pressure is also maintained constant, even when there is wide inlet pressure fluctuation.

Reduction of the operating pressure and maintaining it at a constant level minimizes flow noise in the installation.

Special Features

- DVGW approved
- Up to size 1 1/4" approved for low noise, Group 1 without limitations
- The outlet pressure is set by turning the adjustment knob
- The set pressure is directly indicated on the set point scale
- The adjustment spring is not in contact with the potable water
- The valve insert is of high quality synthetic material and can be fully exchanged
- Integral fine filter
- Also available without fittings
- Easily retrofittable to convert valve to a reverse-rinsing filter combination
- Can be retrofitted with an inlet non-return valve
- Inlet pressure balancing – fluctuating inlet pressure does not influence outlet pressure
- **inService** – Servicing and maintenance without removal from pipework
- Reliable and proven in millions of applications
- Light weight

Construction

The pressure reducing valve comprises:

- Housing with G 1/4" pressure gauge connections on both sides
- Threaded connections (options A & B)
- Valve insert complete with diaphragm and valve seat
- Fine filter with 0.16 mm mesh
- Spring bonnet with adjustment knob and setting scale
- Filter bowl
- Adjustment spring
- Pressure gauge not included (see accessories)

Materials

- Brass housing
- Brass threaded connections
- High-quality synthetic material valve insert
- Stainless steel fine filter mesh
- High-quality synthetic material spring bonnet and adjustment knob
- Clear synthetic or brass filter bowl
- Fibre-reinforced NBR diaphragm
- NBR seals
- Spring steel adjustment spring

Range of Application

Medium:	Water and other non-aggressive liquids, compressed air and nitrogen
Inlet pressure:	Maximum 25.0 bar
Outlet pressure:	1.5 – 6.0 bar

Technical Data

Operating temperature:	Maximum 40 °C with clear filter bowl Maximum 70 °C with brass filter bowl
Minimum pressure drop:	1 bar
Connection sizes:	1/2" to 2"

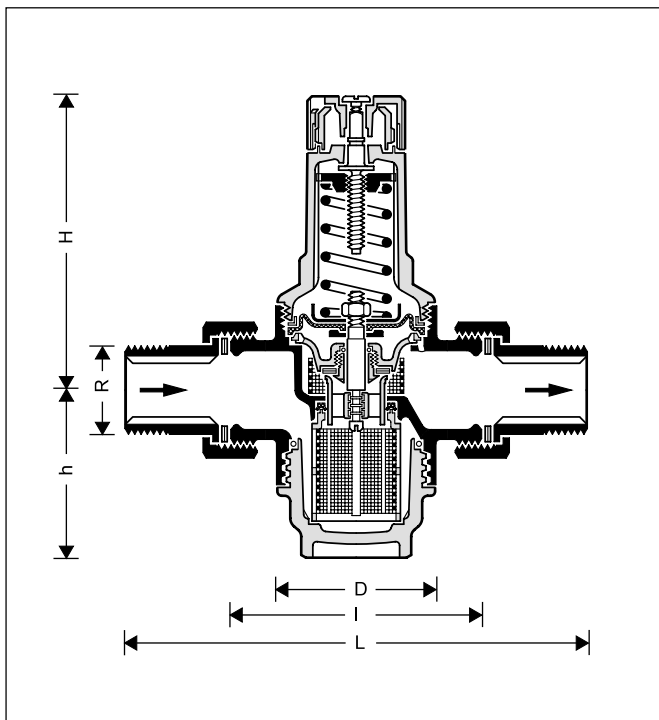

Method of Operation

Spring loaded pressure reducing valves operate by means of a force equalising system. The force of a diaphragm operates against the force of an adjustment spring. If the outlet pressure and therefore diaphragm force fall because water is drawn, the then greater force of the spring causes the valve to open. The outlet pressure then increases until the forces between the diaphragm and the spring are equal again.

The inlet pressure has no influence in either opening or closing of the valve. Because of this, inlet pressure fluctuation does not influence the outlet pressure, thus providing inlet pressure balancing.

Versions

D 06 F- . . . A = With threaded male connections, clear filter bowl – up to 40 °C

D 06 F- . . . B = With threaded male connections, brass filter bowl – up to 70 °C

D 06 F- . . . E = Without fittings, with clear filter bowl – up to 40 °C

Connection size Special versions available on request

Connection size	R	1/2"	3/4"	1"	1 1/4"	1 1/2"	2"
Nominal size	DN	15	20	25	32	40	50
Weight approx. (kg)		0.8	1.0	1.4	2.0	3.3	4.5
Dimensions (mm)	L	140	160	180	200	225	255
	I	80	90	100	105	130	140
	H	89	89	111	111	173	173
	h	58	58	64	64	126	126
	D	54	54	61	61	82	82
	k _{vs} -value		2.4	3.1	5.8	5.9	12.6
Peak flow rate (m ³ /h) according to DIN 1988 Pt 5:	Household installations	1.8	2.9	4.7	7.2	8.3	13.0
	Commercial installations	1.8	3.3	5.4	8.6	13.7	21.2
IfBt No.		P-IX 1582/I	P-IX 1582/I	P-IX 1582/I	P-IX 1582/I	—*	—*
DVGW-Register No.		0432	0433	0896	0435	0436	0437

*Compulsory testing in sizes R 1/2" to R 1 1/4"

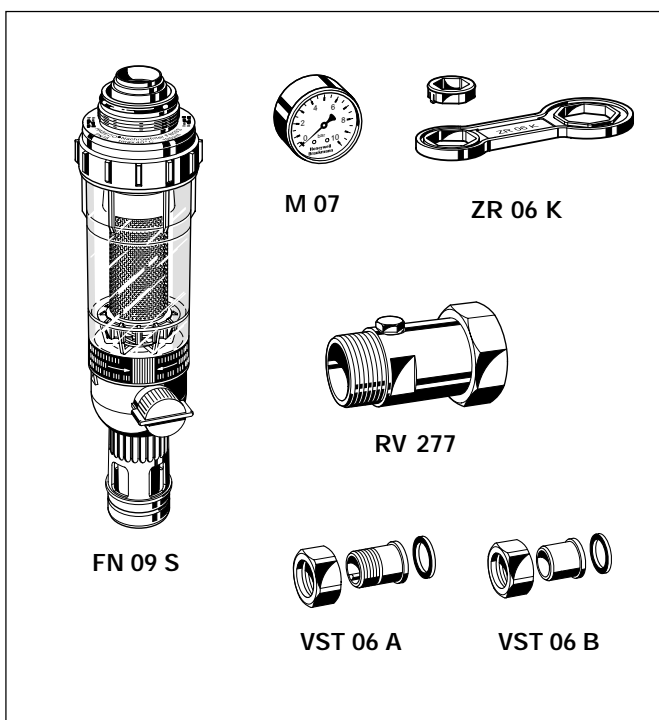

Accessories

FN 09 S HABEDO® Retrofit filter

Reverse-rinsing filter for retro-conversion to a filter combination unit of D 06 F pressure reducing valves made after 1977.

M 07 Pressure gauge

Housing diameter 63 mm, rear connection thread G1/4". Ranges: 0 – 4, 0 –10, 0 – 16 or 0 – 25 bar Please indicate upper value of pressure range when ordering

ZR 06 K Double ring wrench

For removal of spring bonnet and filter bowl of D 06 F valves with connection sizes R 1/2" – 2"

RV 277 Inlet non-return valve

For D 06 F with connection sizes R 3/4" – 2"

VST 06 Connection set

Two threaded or solder connections
A = Threaded connections
B = Solder connections

Installation Example

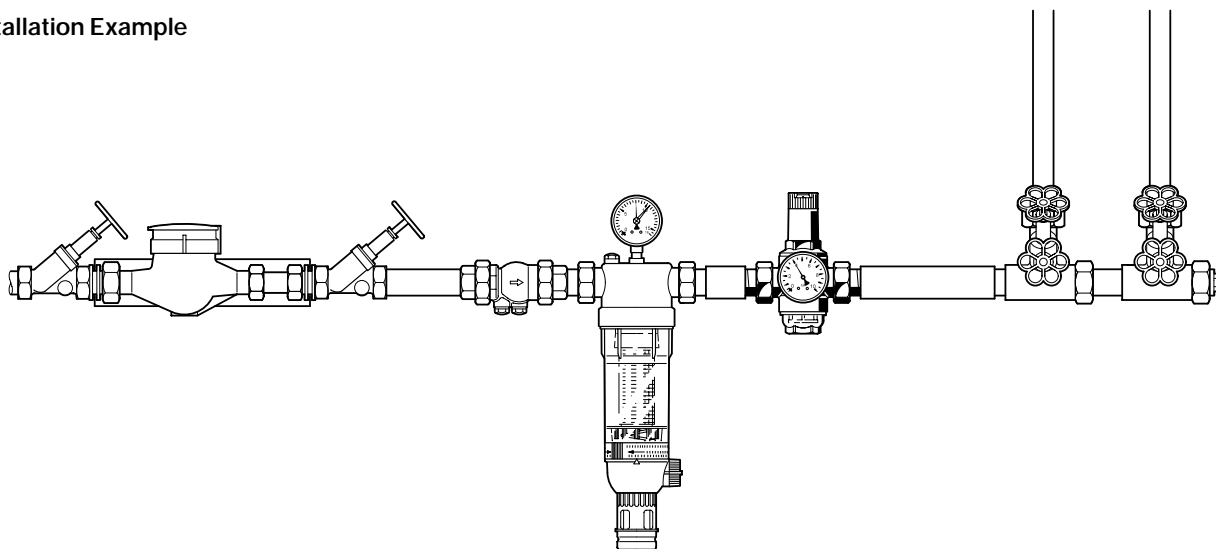

Connection Size	R	1/2"	3/4"	1"	1 1/4"	1 1/2"	2"
W*	(mm)	55	55	55	60	70	70

*Minimum distance from wall to centre line of pipework

Installation Guidelines

- If possible install in horizontal pipework with the filter bowl downwards
 - This is the most effective position for cleaning
- Fit shut off valves
 - This permits **inService** – servicing and maintenance without removal from pipework
- Ensure good accessibility
 - So that the pressure gauge can be easily seen
 - With clear filter bowl, degree of contamination can be easily seen
 - Simplifies maintenance and inspection
- For residential applications where maximum protection against dirt is required, install a fine filter upstream of the pressure reducing valve
- If sufficient space is available, it is recommended that a straight section of pipework of at least five times the nominal valve size is provided after the pressure reducing valve

Typical Applications

D 06 F pressure reducing valves are suitable for all types of household water installations. They can also be used for industrial and commercial applications within the range of their specifications.

Pressure reducing valves should be installed:

- If the static pressure exceeds the maximum permissible value for the system
- As protection against noise if the static pressure at take off points exceeds 5.0 bar (DIN 4109: Noise protection in high buildings)
- If several pressure zones are required when a pressurisation system is used (pressure reducers on each storey of a building)
- If pressure fluctuations in the downstream system must be avoided
- To achieve constant inlet and outlet pressures on pumped pressure boosting systems

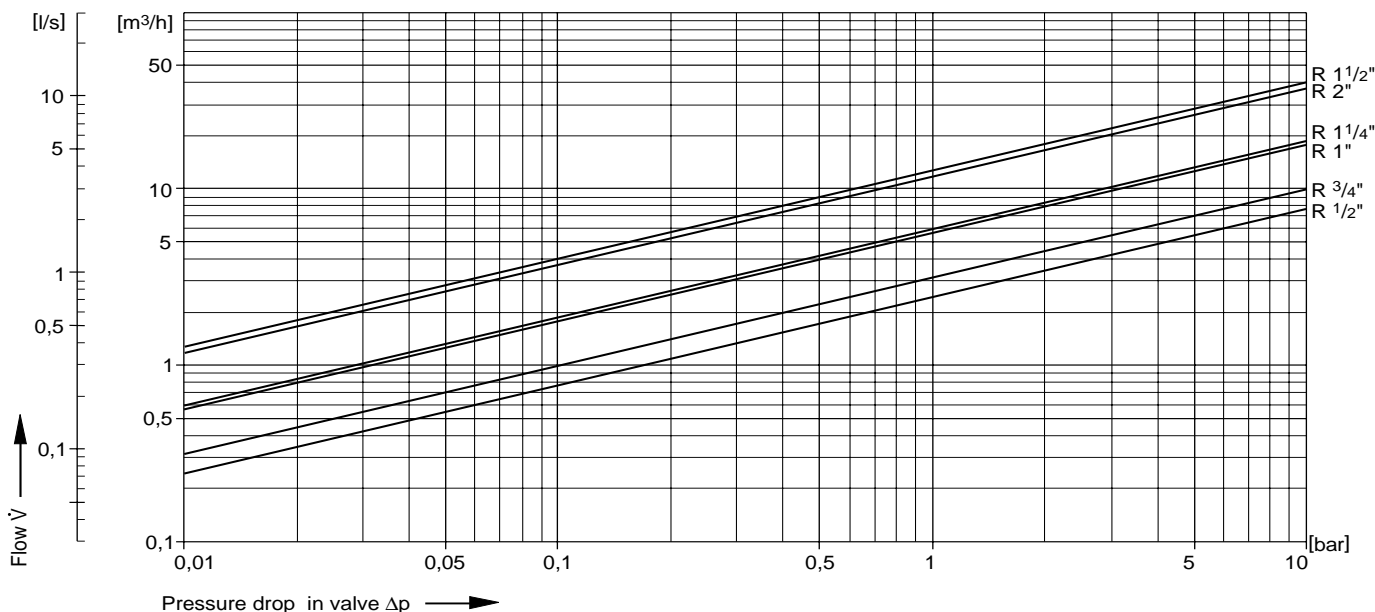

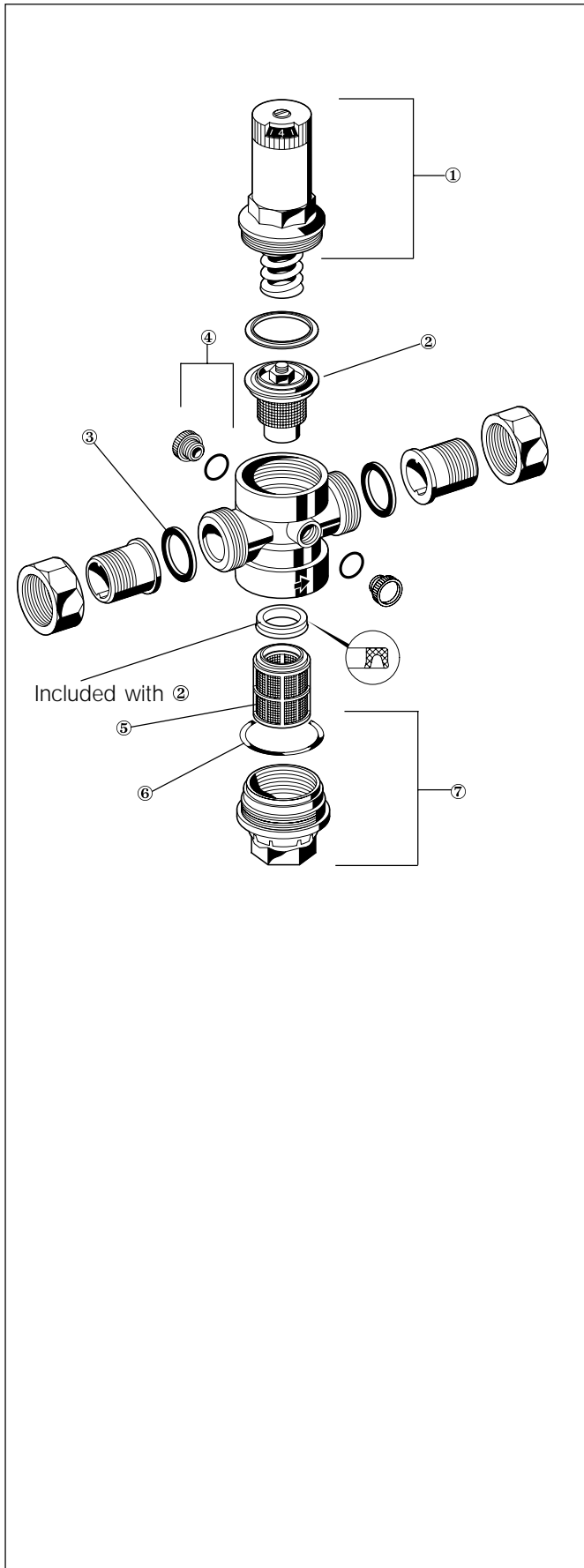

**Spare Parts for D 06 F Pressure Reducing Valves
(From 1997 onwards)**

Description	Nominal size	Part number
① Spring bonnet complete	1/2" + 3/4"	0901515
	1" + 1 1/4"	0901516
	1 1/2" + 2"	0901518
② Valve insert complete (without filter)	1/2" + 3/4"	D 06 FA - 1/2
	1" + 1 1/4"	D 06 FA - 1B
	1 1/2" + 2"	D 06 FA - 1 1/2
③ Gasket ring (10 pcs.)	1/2"	0901443
	3/4"	0901444
	1" + 1 1/4"	0901445
	1 1/2"	0901447
	2"	0901448
④ Blanking plug with O-ring R 1/4" (5 pcs.)	1/2" - 2"	S 06 K - 1/4
⑤ Replacement filter insert	1/2" + 3/4"	ES 06 F - 1/2 A
	1" + 1 1/4"	ES 06 F - 1B
	1 1/2" + 2"	ES 06 F - 1 1/2 A
⑥ O-ring (10 pcs.)	1/2" + 3/4"	0901246
	1" + 1 1/4"	0901499
	1 1/2" + 2"	0901248
⑦ Clear filter bowl with O-ring	1/2" + 3/4"	SK 06 T - 1/2
	1" + 1 1/4"	SK 06 T - 1B
	1 1/2" + 2"	SK 06 T - 1 1/2
⑦ Brass filter bowl with O-ring	1/2" + 3/4"	SM 06 T - 1/2
	1" + 1 1/4"	SM 06 T - 1B
	1 1/2" + 2"	SM 06 T - 1 1/2

Honeywell

Home and Building Control

Honeywell AG
 Hardhofweg · D-74821 Mosbach, Germany
 Phone (49) 6261 81-0 · Fax (49) 6261 81-309

<http://europe.hbc.honeywell.com>